

Smooth Line cylinders
 Double acting
 With or without integrated switches
 Ø` 32 to 100 mm

Smooth and spherical profile design with concealed tie rods

Special polyurethane wiper seal

Body sealing conforms to EN 1672-2

Corrosion resistant design, accepted in the food industry

Electrical connection with M12-connector

Adjustable end position sensing integrated

Integrated rear eye mounting as standard

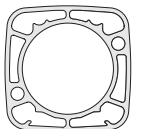

Technical data

Medium:

Compressed air, filtered, lubricated or non-lubricated

Operation:

Double acting, with or without integrated switches, adjustable cushioning

Standard:

ISO 6431, VDMA 24562, NFE 49-003-1

Operating pressure:

1 to 10 bar

Operating temperature:

-20°C to +80°C max.

Consult our Technical Service for use below +2°C

Cylinder diameters:

32, 40, 50, 63, 80 and 100 mm

Strokes:

Standard, see page 2

Non-standard strokes (10 to 3000 mm) available

Switching voltage:

10 to 30 V d.c.

Protection class:

IP66 / IP67 according to EN 60529

Materials

Profile barrel: clear anodised aluminium

End covers: clear anodised aluminium

Piston rod: X10 Cr Ni S 18 9 (AISI 303, 1.4305)

Piston rod nut: X10 Cr Ni S 18 9 (AISI 303, 1.4305)

Cover screws: X10 Cr Ni S 18 9 (AISI 303, 1.4305)

Cover screw seals: PTFE

Barrel seals: X10 Cr Ni S 18 9 (AISI 303, 1.4305) and nitrile rubber

Piston and position rod seals: polyurethane

O-rings: nitrile rubber

M12-plug housing: X10 Cr Ni S 18 9 (AISI 303, 1.4305)

Ordering examples

See page 3

Mountings and switches

See page 3 and 4

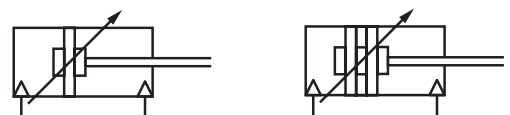

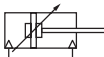
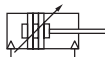
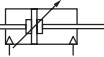

Cylinder variants

Symbol	Model Non-magnetic piston	Symbol	Model Magnetic piston ¹⁾	Description	Page
	PVA/182000		PVA/182000/MI	Standard cylinders	6
	PLA/182000		PLA/182000/MI	Cylinder with special corrosion resistant surface HCR ^{® 2)}	6
	PVA/182000/R		PVA/182000/MI./R	Cylinder with integrated rear eye mounting	7
	PDA/182000		PEA/182000/M	Cylinder with hard chromium plated stainless steel piston rod	6
	PVA/182000/IU		PVA/182000/MU	Cylinder with extended piston rod	6
	PVA/182000/J			Cylinder with double ended piston rod	7

¹⁾ Position of integrated switches, see model codes

²⁾ High technology synergistic coating on request

Standard strokes

Ø mm	25	50	80	100	125	160	200	250	320	400	500
32	●	●	●	●	●	●	●	●	●	●	●
40	●	●	●	●	●	●	●	●	●	●	●
50	●	●	●	●	●	●	●	●	●	●	●
63	●	●	●	●	●	●	●	●	●	●	●
80	●	●	●	●	●	●	●	●	●	●	●
100	●	●	●	●	●	●	●	●	●	●	●

Options selector

P★A/182★/★/★/★/★/★/★

Corrosion protection Standard V Corrosion-resistant surface HCR [®] L Hard chromium plated stainless steel piston rod E	Substitute V L E
Cylinder diameters 32 032 40 040 50 050 63 063 80 080 100 100	Substitute 032 040 050 063 080 100
Variants (with switches) Standard MI Extended piston rod MU P★A/182*** / MU / **** / *** Extension (mm)	Substitute MI MU
Variants (without switches) Standard None Extended piston rod IU Double ended piston rod J P★A/182*** / IU / **** / *** Extension (mm)	Substitute None IU J

Stroke 10 ... 3000, non-magnetic piston 25 ... 3000 magnetic piston	
Mounting variants Standard None Integrated rear eye R	Substitute None R
Variants (with switches) Fixed end position, Reed, M/50/LSU ..1 Fixed end position, Solid state, M/50/EAP ..2 Adjustable end position, Reed, M/50/LSU ..3 Adjustable end position, Solid state, M/50/EAP ..4	Substitute ..1 ..2 ..3 ..4

For combinations of cylinder variants consult our **Technical Service**.

Warning

These products are intended for use in industrial compressed air systems only. Do not use these products where pressures and temperatures can exceed those listed under 'Technical Data'.

Before using these products with fluids other than those specified, for non-industrial applications, life-support systems, or other applications not within published specifications, consult **NORGREN**.

Through misuse, age, or malfunction, components used in fluid power systems can fail in various modes.

The system designer is warned to consider the failure modes of all component parts used in fluid power systems and to provide adequate safeguards to prevent personal injury or damage to equipment in the event of such failure.

System designers must provide a warning to end users in the system instructional manual if protection against a failure mode cannot be adequately provided.

System designers and end users are cautioned to review specific warnings found in instruction sheets packed and shipped with these products.



Switches

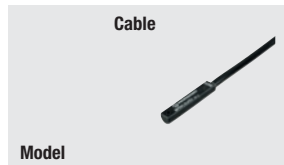

Model

Reed	M/50/LSU/..
Solid state	M/50/EAP/..

Model	Solid state	Voltage V a.c.	V d.c.	Current max.	Temperature °C	LED	Features	Cable/plug	Cable type	Catalogue page
M/50/LSU/*V		10 ... 240	10 ... 170	180 mA	-20° ... +80°	●	–	2, 5 m	PVC 2 x 0,25	N 4.3.005
	M/50/EAP/**V	–	10 ... 30	150 mA	-20° ... +80°	●	PNP	2, 5 m	PVC 3 x 0,25	N 4.3.005

* Insert cable length

Full information on switches (technical data, cable materials, dimensions etc.) please refer to relevant catalogue pages

Ordering examples

Cylinders

To order a standard 80 mm bore magnetic piston cylinder with a 50 mm stroke and fixed end position sensing with Reed switches M/50/LSU quote: **PVA/182080/MI1/50**

Mountings

To order a front flange mounting style G for 80 mm bore, stainless steel material quote: **KQA/8080/22**

Connector cable

With LED

Model	Cable length
M/P73525/2	2m
M/P73525/5	5m
M/P73525/10	10m

Dimensions see page 10

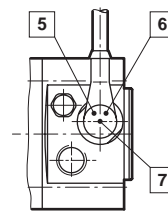

5	Power supply (green)
6	Sensor signal rear end (yellow)
7	Sensor signal front end (yellow)



Mountings

	A	AK	B/G	C	D	D2	F
Ø	Page 8	Page 8	Page 8	Page 8	Page 8	Page 8	Page 9
Corrosion protected							
32	–	–	PVQA/8032/22	–	PVQA/8032/23	–	PVQM/8032/25
40	–	–	PVQA/8040/22	–	PVQA/8040/23	–	PVQM/8040/25
50	–	–	PVQA/8050/22	–	PVQA/8050/23	–	PVQM/8050/25
63	–	–	PVQA/8063/22	–	PVQA/8063/23	–	PVQM/8050/25
80	–	–	PVQA/8080/22	–	PVQA/8080/23	–	PVQM/8080/25
100	–	–	PVQA/8100/22	–	PVQA/8100/23	–	PVQM/8080/25

Alternative versions

Standard							
32	QM/8032/35	QM/8025/38	QA/8032/22	QA/8032/21	QA/8032/23	QA/8032/42	QM/8025/25
40	QM/8032/35	QM/8040/38	QA/8040/22	QA/8040/21	QA/8040/23	QA/8040/42	QM/8040/25
50	QM/8050/35	QM/8050/38	QA/8050/22	QA/8050/21	QA/8050/23	QA/8050/42	QM/8050/25
63	QM/8050/35	QM/8050/38	QA/8063/22	QA/8063/21	QA/8063/23	QA/8063/42	QM/8050/25
80	QM/8080/35	QM/8080/38	QA/8080/22	QA/8080/21	QA/8080/23	QA/8080/42	QM/8080/25
100	QM/8080/35	QM/8080/38	QA/8100/22	QA/8100/21	QA/8100/23	QA/8100/42	QM/8080/25
Stainless steel							
32	–	–	KQA/8032/22	KQA/8032/21	KQA/8032/23	–	KQM/55433/25
40	–	–	KQA/8040/22	KQA/8040/21	KQA/8040/23	–	KQM/55441/25
50	–	–	KQA/8050/22	KQA/8050/21	KQA/8050/23	–	KQM/55451/25
63	–	–	KQA/8063/22	KQA/8063/21	KQA/8063/23	–	KQM/55451/25
80	–	–	KQA/8080/22	KQA/8080/21	KQA/8080/23	–	KQA/8080/25
100	–	–	KQA/8100/22	KQA/8100/21	KQA/8100/23	–	KQA/8080/25

	R	SS	SW	UF	UR	US	Cover screws
Ø	Page 9	Page 10	Page 10	Page 9	Page 9	Page 10	Page 9
With surface treatment							
32	PVQA/8032/27	M/P40465	M/P40459	PVQM/8025/32	PVQA/8032/33	–	–
40	PVQA/8040/27	M/P40466	M/P40460	PVQM/8040/32	PVQA/8040/33	–	–
50	PVQA/8050/27	M/P40467	M/P40461	PVQM/8050/32	PVQA/8050/33	–	–
63	PVQA/8063/27	M/P40468	M/P40462	PVQM/8050/32	PVQA/8063/33	–	–
80	PVQA/8080/27	M/P40469	M/P40463	PVQM/8080/32	PVQA/8080/33	–	–
100	PVQA/8100/27	M/P40470	M/P40464	PVQM/8080/32	PVQA/8100/33	–	–

Alternative versions

Standard							
32	QA/8032/27	M/P19931	M/P19493	QM/8025/32	QA/8032/33	M/P40310	–
40	QA/8040/27	M/P19932	M/P19494	QM/8040/32	QA/8040/33	M/P40311	–
50	QA/8050/27	M/P19933	M/P19495	QM/8050/32	QA/8050/33	M/P40312	–
63	QA/8063/27	M/P19934	M/P19496	QM/8050/32	QA/8063/33	M/P40313	–
80	QA/8080/27	M/P19935	M/P19497	QM/8080/32	QA/8080/33	M/P40314	–
100	QA/8100/27	M/P19936	M/P19498	QM/8080/32	QA/8100/33	M/P40315	–
Stainless steel							
32	–	–	M/P72288	–	–	–	PVQA/182032/88
40	–	–	M/P72289	–	–	–	PVQA/182032/88
50	–	–	M/P72290	–	–	–	PVQA/182050/88
63	–	–	M/P72291	–	–	–	PVQA/182050/88
80	–	–	M/P72292	–	–	–	PVQA/182080/88
100	–	–	M/P72293	–	–	–	PVQA/182080/88



Materials and surface treatment of mountings and accessories

Standard cylinders

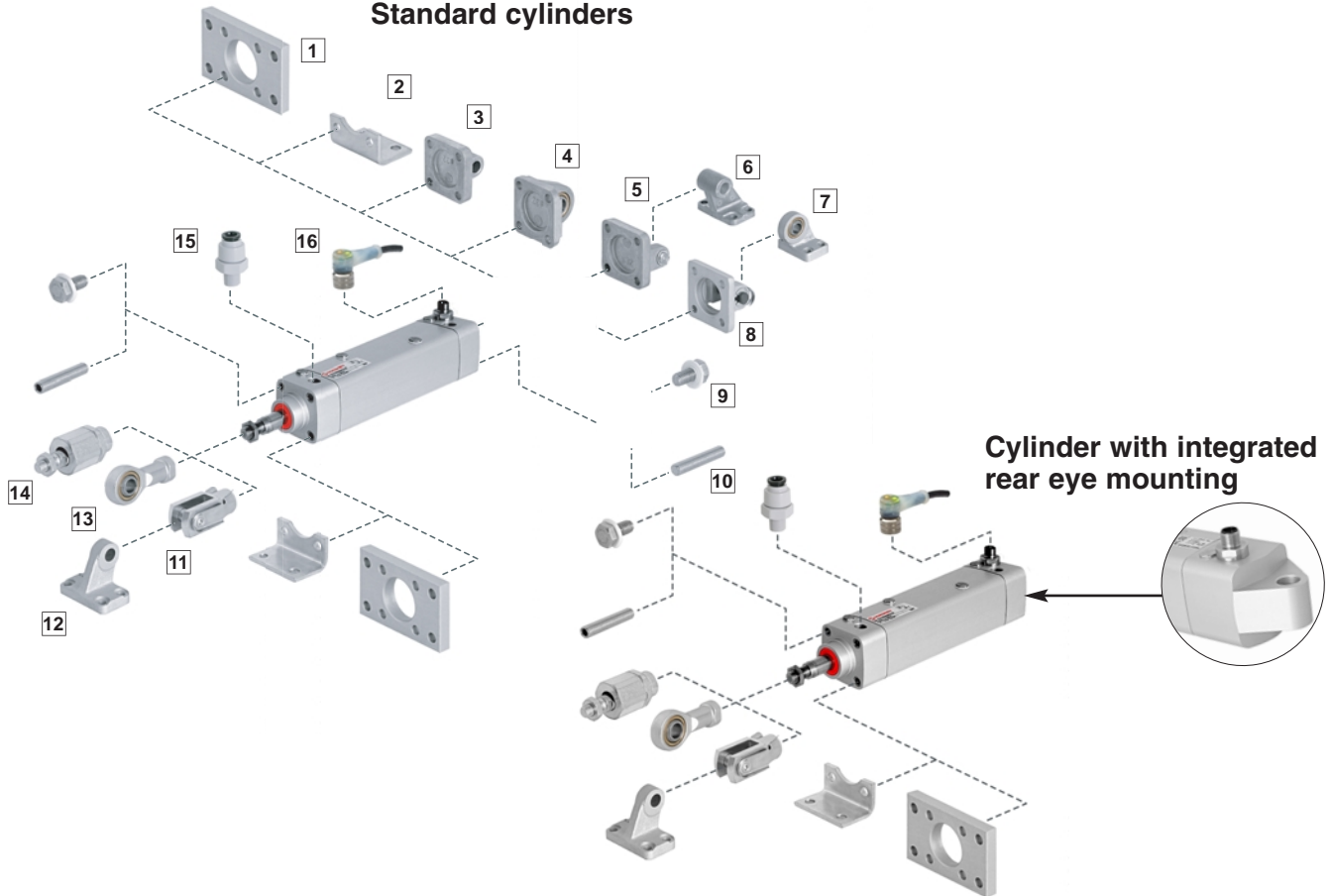

Recommended mounting range

Position	Style	Corrosion protected
1	B, G	Clear anodised aluminium. Screws: A2
2	C	-
3	R	Black corrosion protected diecast aluminium Certified for the food industry. Screws: A2
4	UR	Black corrosion protected diecast aluminium Certified for the food industry Inner ring: stainless Steel (Austenitic) Outer ring: nickel plated hardened steel
5	D	Black corrosion protected diecast aluminium Certified for the food industry Bolt: X 10 Cr Ni S 18 9 (1.4305, AISI 303) Circlip: Stainless steel (Martensitic). Screws: A2
6	SW	Black corrosion protected diecast aluminium Certified for the food industry
7	US	-
8	D2	-
9	Cover screws	-
10	A	-
11	F	Nickel plated steel Circlip: X 10 Cr Ni S 18 9 (1.4305, AISI 303) Bolt: X 10 Cr Ni S 18 9 (1.4305, AISI 303)
12	SS	Cast iron nickel plated
13	UF	Nickel plated steel. Inner ring: stainless steel (Austenitic) Outer ring: nickel plated hardened steel
14	AK	-
15	Fittings	Acetal co-polymer M90-04 kemetal Grab ring: stainless steel. Catalogue page 9.4.001
16	Connector cable	-

Alternative mounting range

Standard	Stainless steel
Clear anodised aluminium	X 5 Cr Ni 18 10 (1.4301; AISI 304). Screws: A2
Galvanized steel (Ø 32 to 63 mm) Painted steel (Ø 80 & 100 mm)	X 5 Cr Ni 18 10 (1.4301; AISI 304). Screws: A2
Diecast aluminium	-
Galvanized aluminium Inner ring: steel Outer ring: brass	-
Diecast aluminium Bolt: galvanized steel (Martensitic) Circlip: galvanized steel	X 5 Cr Ni 18 10 (1.4301; AISI 304). Screws: A2. Bolt: X 10 Cr Ni S 18 9 (1.4305; AISI 303)
Diecast aluminium	G-X 6 Cr Ni 18 9 (1.4308; AISI 304)
Galvanized aluminium. Inner ring: steel Outer ring: brass	-
Painted cast iron. Bolt: stainless steel (Martensitic) Circlip: galvanized steel	-
-	X 10 Cr Ni S 18 9 (1.4305, AISI 303)
Galvanized steel	-
Galvanized steel Bolt: galvanized steel Circlip: Galvanized steel	X 10 Cr Ni S 18 9 (1.4305; AISI 303) Bolt: X 10 Cr Ni S 18 9 (1.4305; AISI 303) Eyebolt: X 10 Cr Ni S 18 9 (1.4305; AISI 303)
Painted cast iron	-
Galvanized steel. Inner ring: steel Outer ring: brass	-
Galvanized steel	-
Body: PBT & nickel plated brass. Grab ring: stainless steel. Release sleeve: POM. Catalogue page 9.2.001	Body and grab ring: stainless steel. Release sleeve: acetal O-Ring: Viton. Catalogue page 9.3.001
-	Cable and housing: PVC Nut: X10 Cr Ni S 18 9 (AISI 303, 1.4305)



Theoretical forces • Cushioning • Air consumption

Ø	Theoretical forces (N) at 6 bar		Cushion length (mm)	Initial cushion volume (cm³)	Air consumption (cm³) at 6 bar	
	Outstroke	Instroke			Outstroke	Instroke
32	482	414	13	8,5	0,056	0,048
40	754	633	17	16	0,088	0,074
50	1178	990	22	33	0,137	0,114
63	1870	1680	22	58	0,218	0,195
80	3016	2722	27	116	0,35	0,32
100	4710	4416	34	242	0,55	0,51

PVA/182000/...

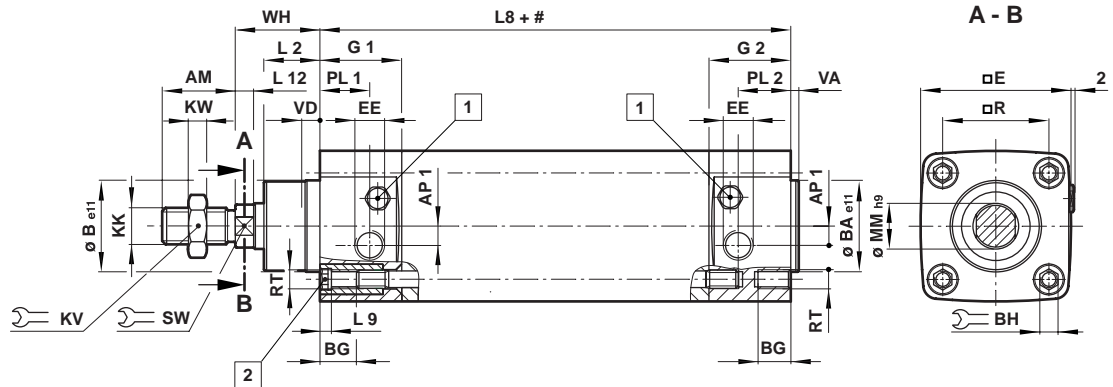

PVA/182000/M../..

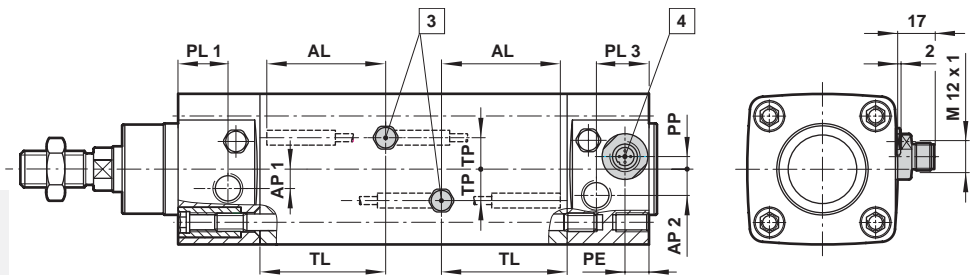

- # Stroke
- 1 Cushion screw
- 2 Torques for mounting screws
 Ø 32 + 40mm 4,5 – 5 Nm
 Ø 50 + 63mm 12 – 15 Nm
 Ø 80 + 100mm 23 – 26 Nm
- 3 Adjustable length AL for
 PVA/182000/M.3, M.4 only

Stroke	AL	TL
< 80	30	35
≥ 80	50	55
- 4 4 x 90° rotatable

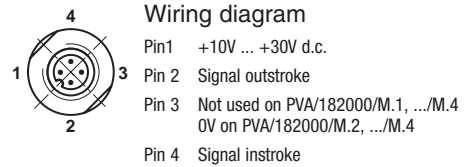

Model	Ø	AM	AP1	AP2	Ø B e11	Ø BA e11	BG	BH	E	EE	G1	G2
PVA/182032	32	22	6	7,5	30	30	16	6	48	G1/8"	27	33
PVA/182040	40	24	6,5	8,5	35	35	16	6	55	G1/4"	35,5	35,5
PVA/182050	50	32	8,5	11,5	40	40	16	8	66	G1/4"	36	36
PVA/182063	63	32	11	14,5	45	45	16	8	77	G3/8"	40,5	40,5
PVA/182080	80	40	15,5	19,5	45	45	16	10	96,5	G3/8"	41	41
PVA/182100	100	40	15,5	22	55	55	16	10	117	G1/2"	46	46

Model	Ø	KK	KV	KW	L2	L8	L9	L12	Ø MM h9	PE	PL1	PL2
PVA/182032	32	M10 x 1,25	17	5	18	94	4	6	10	10,5	16	22
PVA/182040	40	M12 x 1,5	19	6	20	105	4	6,5	12	10,5	21,5	21,5
PVA/182050	50	M16 x 1,5	24	8	24,5	106	5	8	12	10,5	22	22
PVA/182063	63	M16 x 1,5	24	8	24,5	121	5	8	16	11	24,5	24,5
PVA/182080	80	M20 x 1,5	30	10	32,5	128	5,5	10	16	11	25	25
PVA/182100	100	M20 x 1,5	30	10	35,5	138	5,5	10	20	11	27	27

Model	Ø	PL3	PP	R	RT	SW	TP	VA	VD	WH	kg at 0 mm	kg per 25 mm
PVA/182032	32	24,5	2,3	32,5	M6	10	10,5	3	6	26	0,64	0,07
PVA/182040	40	23,5	6,6	38	M6	13	13	3,5	6	30	0,95	0,09
PVA/182050	50	23	5,5	46,5	M8	17	14	3,5	6	37	1,51	0,13
PVA/182063	63	24,5	4,5	56,5	M8	17	18	4	6	37	2,10	0,15
PVA/182080	80	25	0	72	M10	22	18,5	4	6	46	3,75	0,23
PVA/182100	100	27	0	89	M10	22	19,5	4	6	51	5,61	0,26



PVA/182000/.../R

with integrated rear eye mounting and with magnetic sensing

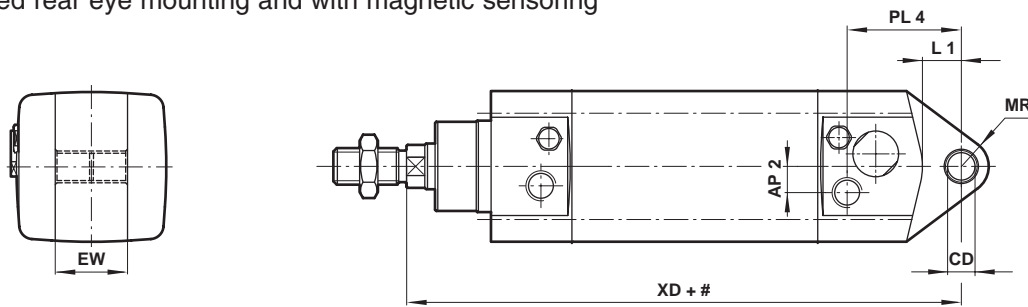

PVA/182000/M.../R..

with integrated rear eye mounting and with magnetic sensing

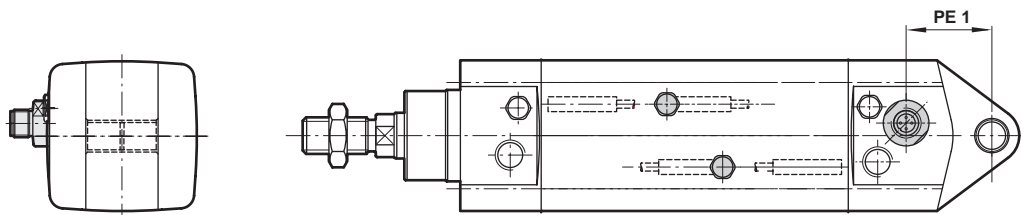

Model	Ø	AP2	Ø CD	EW -0,4	L1	MR	PE1	PL4	XD	kg at 0 mm	kg per 25 mm
PVA/182032/.../R	32	7,5	10	25,8	12,5	10	32,5	46,5	142	0,70	0,07
PVA/182040/.../R	40	8,5	12	27,8	15,5	12	35,5	48,5	160	1,04	0,09
PVA/182050/.../R	50	11,5	12	31,8	17	12	37,5	50	170	1,65	0,13
PVA/182063/.../R	63	14,5	16	39,8	22	15	43	56,5	190	2,33	0,15
PVA/182080/.../R	80	19,5	16	49,8	21	15	47	61	210	3,96	0,23
PVA/182100/.../R	100	22	20	59,8	27	20	52	68	230	5,93	0,26

For other dimensions see page 6

PVA/182000/J

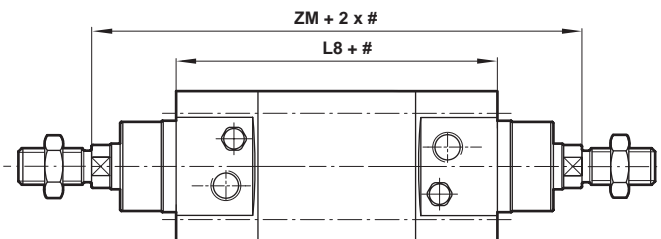

#	Stroke
---	--------

Model	Ø	L8	ZM	kg at 0 mm	kg per 25 mm
PVA/182032/J	32	105	165	1,09	0,13
PVA/182040/J	40	105	165	1,09	0,13
PVA/182050/J	50	106	180	1,77	0,19
PVA/182063/J	63	121	195	2,39	0,21
PVA/182080/J	80	128	220	3,96	0,33
PVA/182100/J	100	138	240	5,82	0,36

For other dimensions see page 6



Front or rear stud A

(Corresponds to DIN ISO 6431, Style MX1)

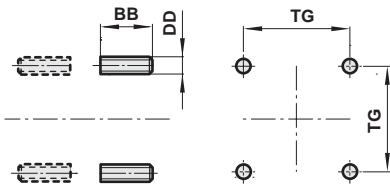

Model (A)	Ø	BB	DD	TG	kg
QM/8032/35	32/40	17	M 6	32,5	0,02
QM/8050/35	50/63	23	M 8	46,5	0,05
QM/8080/35	80/100	28	M 10	72	0,08

Piston rod swivel AK

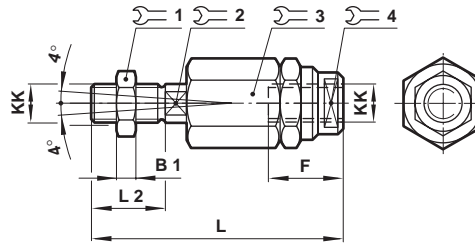

Model (AK)	Ø	Thread KK	B1	F	L	L2	1	2	3	4	kg
QM/8025/38	32	M 10 x 1,25	5	26	73	20	19	12	17	30	0,2
QM/8040/38	40	M 12 x 1,25	6	26	77	24	19	12	19	30	0,2
QM/8050/38	63	M 16 x 1,5	8	34	106	32	30	19	24	42	0,65
QM/8080/38	100	M 20 x 1,5	10	42	122	40	30	19	30	42	0,72

Rear flange B, Front flange G

(Corresponds to DIN ISO 6431 and VDMA 24562 Part 2, Style MF1 and MF2)

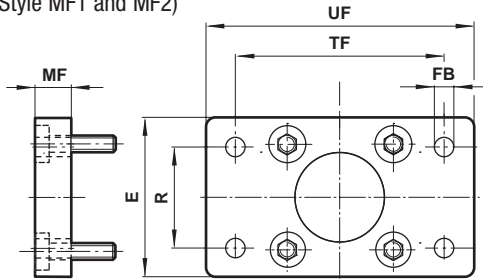

Model (B - G)	Ø	E1	Ø FB	MF	R	TF	UF	kg
PVQA/8032/22	32	50	7	10	32	64	80	0,25
PVQA/8040/22	40	55	9	10	36	72	90	0,35
PVQA/8050/22	50	65	9	12	45	90	110	0,70
PVQA/8063/22	63	75	9	12	50	100	125	0,80
PVQA/8080/22	80	100	12	16	63	126	154	1,35
PVQA/8100/22	100	120	14	16	75	150	186	2,20

Foot C

(Corresponds to DIN ISO 6431 and VDMA 24562 Part 2, Style MF1)

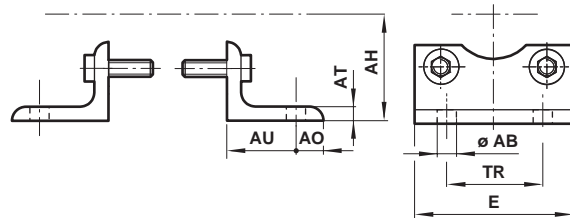

Stainless steel									
Model (C)	Ø	Ø AB	AH	AO	AT	AU	E	TR	kg
KQA/8032/21	32	7	32	11	4	24	48	32	0,15
KQA/8040/21	40	9	36	12	5	28	53	36	0,19
KQA/8050/21	50	9	45	13	5	32	64	45	0,32
KQA/8063/21	63	9	50	13	5	32	74	50	0,41
KQA/8080/21	80	12	63	19	6	41	98	63	0,83
KQA/8100/21	100	14	71	19	6	41	115	75	0,98
Standard									
QA/8032/21	32	7	32	8	4	24	48	32	0,15
QA/8040/21	40	9	36	9	4	28	53	36	0,19
QA/8050/21	50	9	45	10	5	32	64	45	0,32
QA/8063/21	63	9	50	12	5	32	74	50	0,41
QA/8080/21	80	12	63	19	5	41	98	63	0,83
QA/8100/21	100	14	71	19	5	41	115	75	0,98

Rear clevis D

(Corresponds to DIN ISO 6431 and VDMA 24562 Part 2, Style MF1 and MF2)

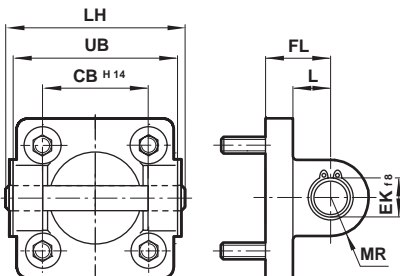

Model (D)	Ø	CB ^{H14}	ØEK _{1/8}	FL	L	LH	MR	UB	kg
PVQA/8032/23	32	26	10	22	13	52	9	45	0,11
PVQA/8040/23	40	28	12	25	16	60	9	52	0,16
PVQA/8050/23	50	32	12	27	17	68	12	60	0,22
PVQA/8063/23	63	40	16	32	22	79	15	70	0,34
PVQA/8080/23	80	50	16	36	22	99	15	90	0,54
PVQA/8100/23	100	60	20	41	27	119	20	110	0,90

Rear clevis D2

(Corresponds to VDMA 24562 Part 2)

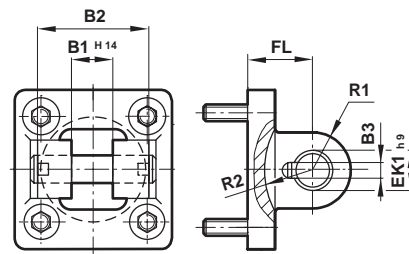

Model (D2)	Ø	B1 ^{H14}	B2	B3	ØEK _{h9}	FL	R1	R2	kg
QA/8032/42	32	14	34	3,3	10	22	11	17	0,20
QA/8040/42	40	16	40	4,3	12	25	12	20	0,23
QA/8050/42	50	21	45	4,3	16	27	14,5	22	0,36
QA/8063/42	63	21	51	4,3	16	32	18	25	0,55
QA/8080/42	80	25	65	4,3	20	36	22	30	0,90
QA/8100/42	100	25	75	6,3	20	41	22	32	1,45



Piston rod clevis F

(Corresponds to DIN ISO 8140)

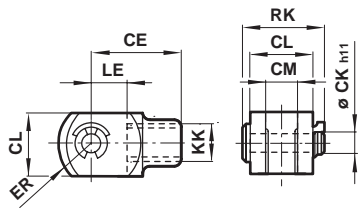

Model (F)	Ø	Thread KK	CE	ØCK h11	CL	CM	ER	LE	RK	kg
PVQM/8025/25	32	M10x1,25	40	10	20	10	16	20	28	0,09
PVQM/8040/25	40	M12x1,25	48	12	24	12	19	24	32	0,13
PVQM/8050/25	50/63	M16x1,5	64	16	32	16	25	32	41,5	0,33
PVQM/8080/25	80/100	M20x1,5	80	20	40	20	32	40	50	0,67

Rear eye R

(Corresponds to DIN ISO 6431 and VDMA 24562 Part 2, Style MP4)

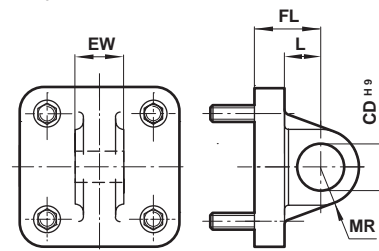

Model (R)	Ø	Ø CD ^{H9}	EW	FL	L	MR	kg
PVQA/8032/27	32	10	25,8	22	13	9	0,09
PVQA/8040/27	40	12	27,8	25	16	12	0,11
PVQA/8050/27	50	12	31,7	27	17	12	0,17
PVQA/8063/27	63	16	39,7	32	22	15	0,24
PVQA/8080/27	80	16	49,7	36	22	15	0,37
PVQA/8100/27	100	20	59,7	41	27	20	0,59

Universal piston rod eye UF

(Corresponds to DIN ISO 8139)

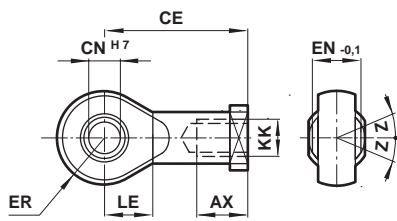

Model (UF)	Ø	Thread KK	AX	CE	ØCN ^{H7}	EN-0,1	ER	LE	Z	kg
PVQM/8025/32	32	M10x1,25	20	43	10	14	14	15	13°	0,09
PVQM/8040/32	40	M12x1,25	22	50	12	16	16	17	13°	0,13
PVQM/8050/32	50/63	M16x1,5	28	64	16	21	21	22	15°	0,33
PVQM/8080/32	80/100	M20x1,5	51	110	30	37	35	36	15°	1,35

Universal rear eye UR

(Corresponds to VDMA 24562 Part 2)

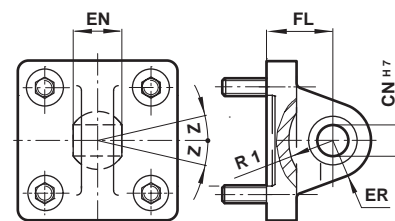

Model (UR)	Ø	ØCN ^{H7}	EN	ER	FL	R	Z	kg
PVQA/8032/33	32	10	14	16	22	14,5	13°	0,15
PVQA/8040/33	40	12	16	19	25	18	13°	0,25
PVQA/8050/33	50	16	21	21	27	19	13°	0,40
PVQA/8063/33	63	16	21	24	32	24	15°	0,55
PVQA/8080/33	80	20	25	28	36	24	15°	0,90
PVQA/8100/33	100	20	25	30	41	29	15°	1,50

Cover screws

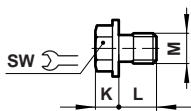

Model	Ø	M	SW	K	L	kg
PVQA/182032/88	32/40	M6	10	5,5	10,5	0,018
PVQA/182050/88	50/63	M8	13	6,8	10,5	0,041
PVQA/182080/88	80/100	M10	17	8,4	10	0,072



Swivel hinge US

(Corresponds to VDMA 24562 Part 2)

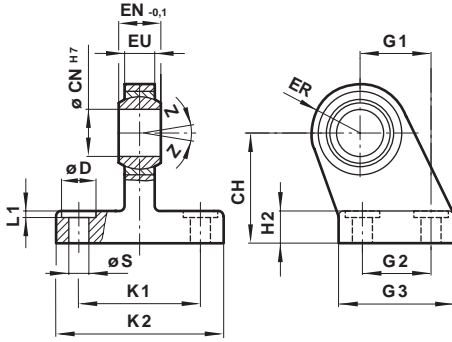

Narrow hinge SS

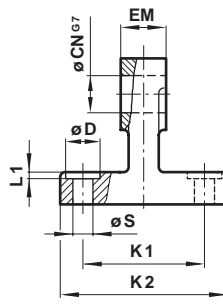

Wide hinge SW

(Corresponds to VDMA 24562 Part 2)

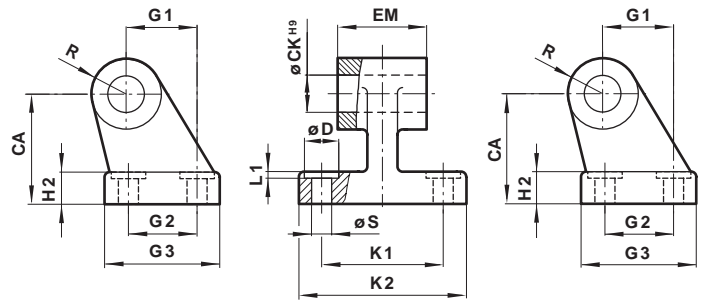

Model (US)	Ø	CH	Ø CN ^{H7}	Ø D	EN- _{0,1}	ER	EU	G1	G2	G3	H2	K1	K2	L1	Ø S	Z	kg
M/P40310	32	32	10	11	14	16	10,5	21	18	31	8	38	51	1,6	6,6	13°	0,19
M/P40311	40	36	12	11	16	19	12	24	22	35	10	41	54	1,6	6,6	13°	0,24
M/P40312	50	45	16	15	21	21	15	33	30	45	12	50	65	1,6	9	13°	0,46
M/P40313	63	50	16	15	21	24	15	37	35	50	12	52	67	1,6	9	15°	0,59
M/P40314	80	63	20	18	25	28	18	47	40	60	14	66	86	2,5	11	15°	1,03
M/P40315	100	71	20	18	25	30	18	55	50	70	15	76	96	2,5	11	15°	1,40
Model (SS)	Ø	CA	Ø CN ^{Ø7}	Ø D	H2	EM	G1	G2	G3	K1	K2	L1	R	Ø S	kg		
M/P19931	32	32	10	11	8	10	21	18	31	38	51	1,6	10	6,6	0,15		
M/P19932	40	33	12	11	10	12	24	22	35	41	54	1,6	11	6,6	0,20		
M/P19933	50	45	16	15	12	16	33	30	45	50	65	1,6	13	9	0,48		
M/P19934	63	50	16	15	12	16	37	35	50	52	67	1,6	15	9	0,50		
M/P19935	80	63	20	18	14	20	47	40	60	66	86	2,5	15	11	0,75		
M/P19936	100	71	20	18	15	20	55	50	70	76	96	2,5	19	11	1,20		
Model (SW)	Ø	CA	Ø CK ^{H9}	Ø D	H2	EM	G1	G2	G3	K1	K2	L1	R	Ø S	kg		
M/P40459	32	32	10	11	8	26	21	18	31	38	51	1,6	10	6,6	0,05		
M/P40460	40	36	12	11	10	28	24	22	35	41	54	1,6	11	6,6	0,07		
M/P40461	50	45	12	15	12	32	33	30	45	50	65	1,6	13	9	0,14		
M/P40462	63	50	16	15	12	40	37	35	50	52	67	1,6	15	9	0,18		
M/P40463	80	63	16	18	14	50	47	40	60	66	86	2,5	15	11	0,28		
M/P40464	100	71	20	18	15	60	55	50	70	76	96	2,5	19	11	1,42		



Spares

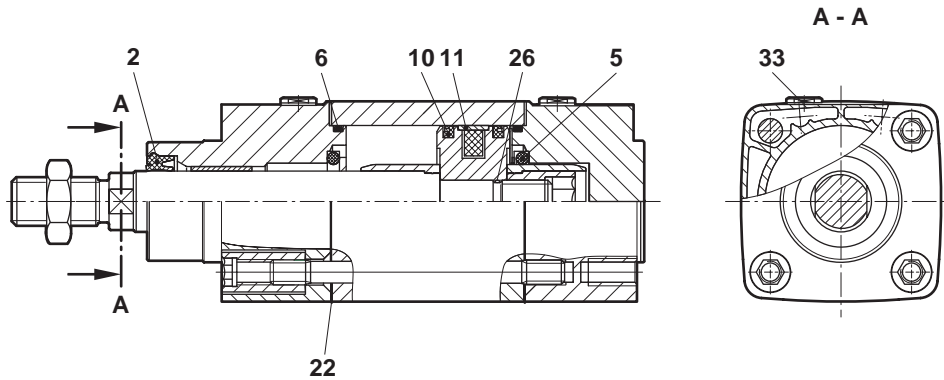

Ø	Model	Spares kit	Item	Comprising Description	Quantity	Piston rod
32	PVA/182032...	PVQA/182032/00	2	Piston rod seal	1	SM/P73610/*
40	PVA/182040...	PVQA/182040/00	5	Cushion seal	2	SM/P19967/*
50	PVA/182050...	PVQA/182050/00	6	Sealing ring	2	SM/P19968/*
63	PVA/182063...	PVQA/182063/00	10	Piston seal	2	SM/P19969/*
80	PVA/182080...	PVQA/182080/00	11	Wear ring	1	SM/P19970/*
100	PVA/182100...	PVQA/182100/00	22	profile seal	2	SM/P19971/*
			26	'O'-ring	1	
			33	seal ring	2	

* Insert stroke length

Please quote the cylinder type number when ordering spares kits and piston rods.

Spares for end position sensing

Model	Switches	Assembly kit for 2 switches	Description	Quantity
P.A/182.../M.1	M/50/LSU/2V*	PVQA/182000/M/64	Switches holders	2
P.A/182.../M.3			fixing screws assys.	2
P.A/182.../M.2	M/50/EAP/2V*	PVQA/182000/M/64	'O'-ring for plug M12	1
P.A/182.../M.4			Assembly instructions	1

Please order .../5 (5 m cable length) for cylinder with strokes ≥ 1800 mm

Please quote the switches type number, when ording spares for end position sensing